

# LumiScan<sup>x</sup>

## Data Sheet

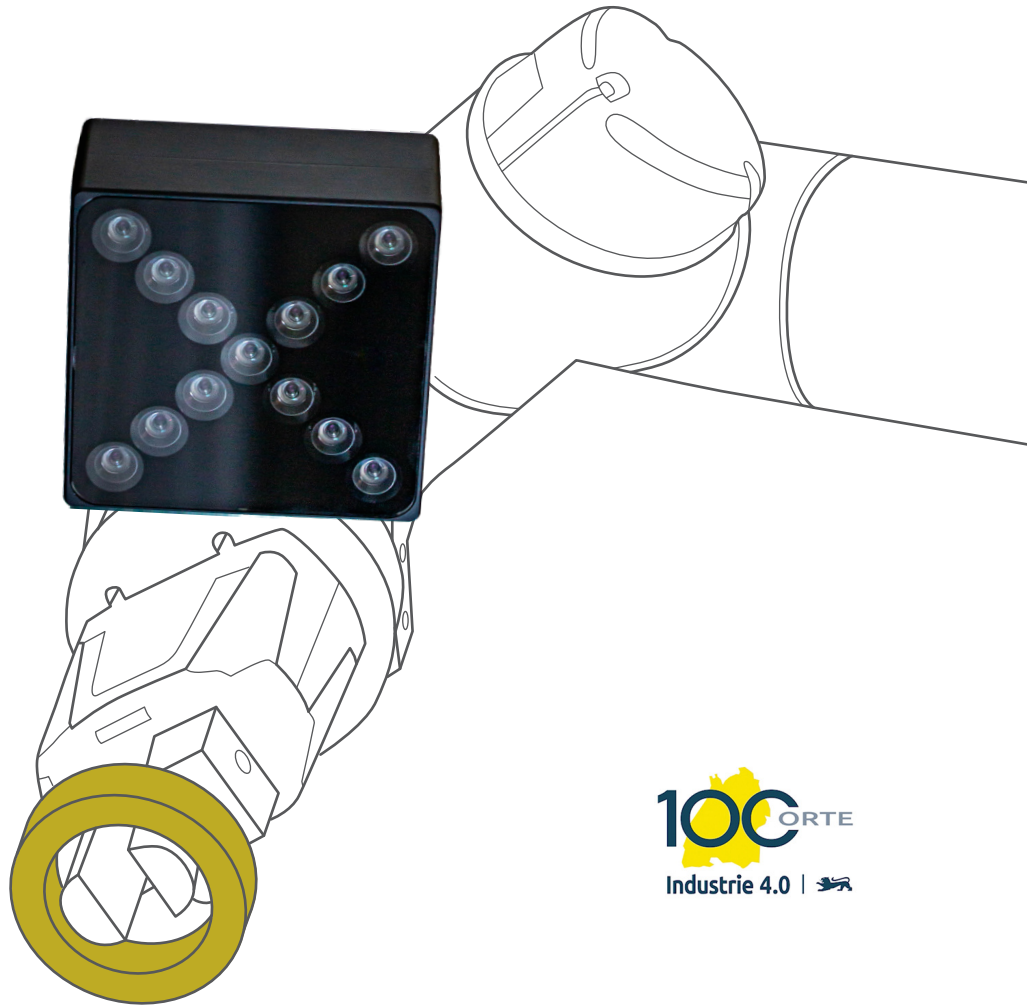

**HD Vision Systems** develops sensors and software for optical measurement and reconstruction of objects and surfaces in regards to quality inspection and robot vision.

**LumiScanX** is more reliable and generates more precise depth values than comparable technologies – especially on shiny and metallic surfaces.

Special about the **LumiScan range of products** are the flexibility, compactness and independence of lighting conditions.

LumiScanX - the **innovation** for quality inspection and robot vision!

# Light Field Sensors for Robots

Article number: LumiScan<sup>X</sup>60 / LumiScan<sup>X</sup>40 / LumiScan<sup>X</sup>30

## System

Resolution (depth map)	1,2 MP (1280 x 960)
Point-to-point distance at 1 m edge measurement field	0,84 mm
Calibration accuracy	≤ 0,50 mm (at 1 m edge measurement field)
Temporal Z noise	≤ 0,50 mm (at 1 m edge measurement field)
Maximum frame rate	6 fps
Single Capture / Snapshot	1000 μs
Acquisition time (object detection)	1 s
Recommended measuring distance	300 – 3000 mm
3D point throughput camera-array	7.2 Million points per second 13 x 1.2 MPix, Monochrome, 12 Bit

## Options

cables	Power / Data / Sync
Software modules	Various analysis modules
Integration	<ul style="list-style-type: none"> <li>• OPC-UA</li> <li>• ProfiNet</li> <li>• Common image processing solutions such as Halcon and Matlab via GenTL</li> <li>• SDK, example code</li> </ul>

## Interfaces

Data	Gigabit Ethernet, 8-pin M12 socket
GPIO	24 V DC, trigger I/O (opto-decoupled), 5-pin M12 connector
Power supply	24 V DC or PoE (IEEE 802.3af)
Power consumption (typical)	5,5 Watt
Standards	GigE Vision, GenICam, GenTL
Operation modes	free-run, hardware trigger, software trigger

## Casing

Dimensions	112 x 112 x 56 mm
Weight	737 g
Protection	IP54

## Add-Ons

Lighting modules	Application-specific light sources and modules
------------------	--

## Environmental Conditions

Operating temperature	0 °C – 55 °C
Storage temperature	0 °C – 65 °C
Relative humidity (not condensing)	5 % – 85 %

## Opening angle for the 3 variants in x and y direction

	X	Y
LumiScan <sup>X</sup> 60	60°	45°
LumiScan <sup>X</sup> 40	40°	35°
LumiScan <sup>X</sup> 30	30°	20°

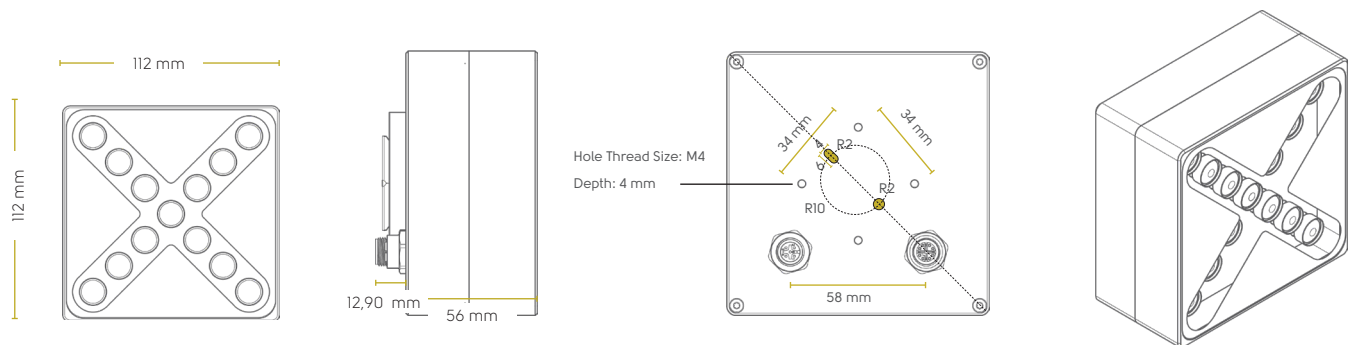

**HD Vision Systems GmbH**  
 Palo-Alto-Platz 11 | 69124 Heidelberg  
 T +49 6221 6721900

info@hdvisionsystems.com | [www.hdvisionsystems.com](http://www.hdvisionsystems.com)

## Robot Control

Due to the robust detection and precise localisation of complex objects, LumiScanX enables the solution of diverse tasks in robot control. The dense point cloud enables collision-free approach and prioritisation of the objects to be grasped, which are recognised via CAD matching or reference model matching. Interfaces such as Profinet and OPC-UA facilitate integration.

## Quality Inspection

When inspecting complex components and random samples, objects are compared with the CAD data and defects are detected. Our viewer shows the reference model in the measured, coloured point cloud. Deviations or surface defects are detected and classified with AI (Deep Learning). In applications such as incoming goods inspection or quality inspection, IO/NIO decisions are made fully automated.

**HD Vision Systems GmbH**

Palo-Alto-Platz 11 | 69124 Heidelberg

T +49 6221 6721900

info@hdvisionsystems.com | [www.hdvisionsystems.com](http://www.hdvisionsystems.com)